

Valve Flange

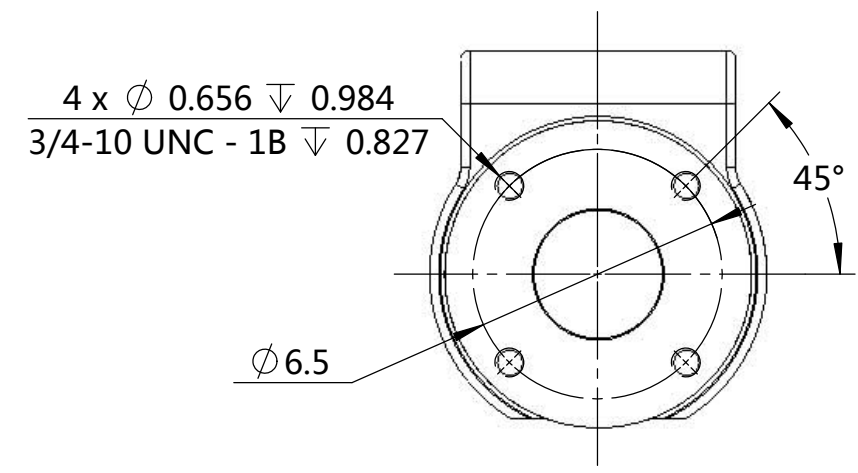

**Stem and Key
18"**

**Stem and Key
20"**

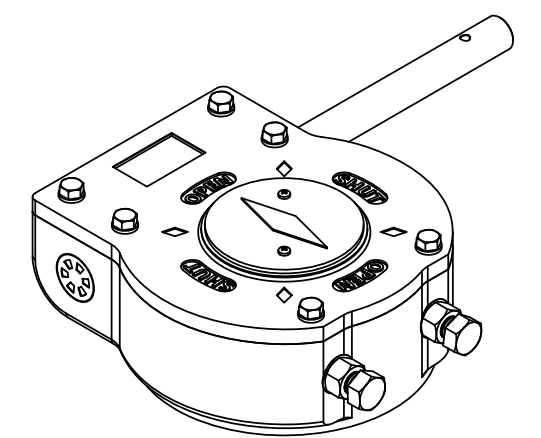
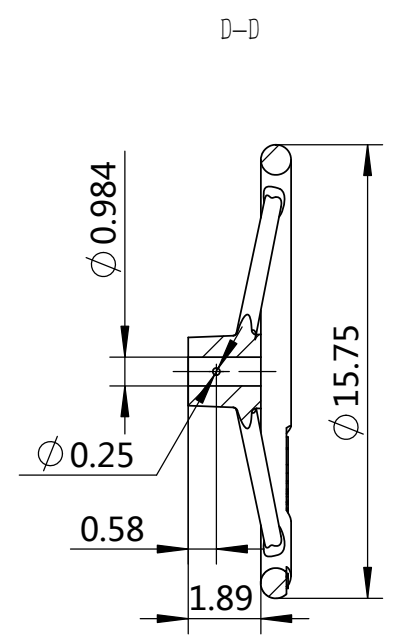
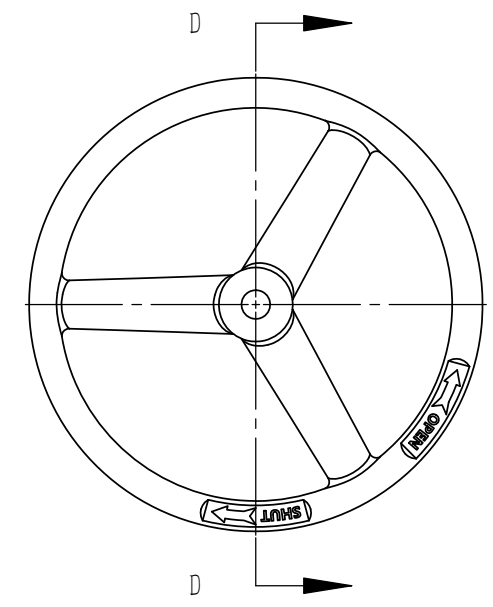
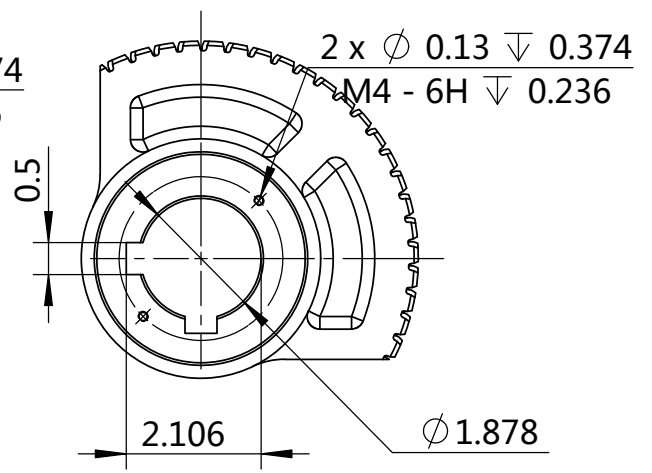
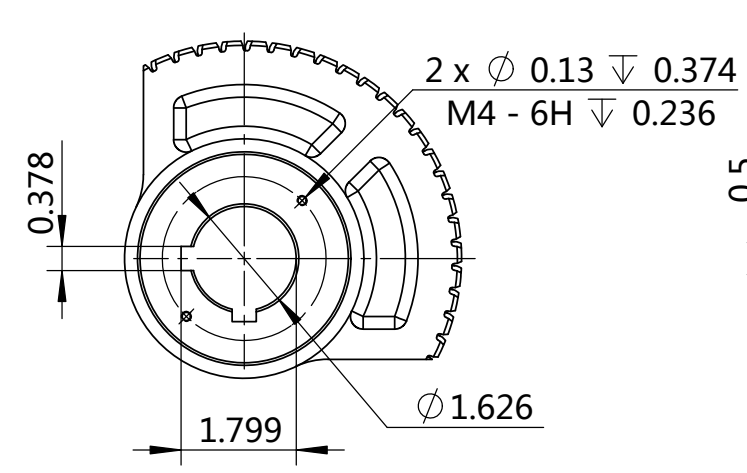

Mod.	Valves	Technical Data	
EM 40	PRATT 18"-20"	Max. Output Torque (lbf-in)	26550
		Max. Input Torque (lbf-in)	1500
		Ratio	55:1
		Weight	20 Kg

PROJECT NAME: Gears		Material:		 Pratt Industrial 3700 Oakes Drive, Suite B Emporia, KS 66801
SIGNATURE	DATE	WEIGHT: Kg		
DESIGN	10/06/14	Q.A.:		TITLE: Gear Drawing
DRAW		Phase marker		DWG NO. EM40-00
CHK'D		A		A3
CRAFT		REV:		SCALE: 1:5
APPR				PAGE: 1 OF 1