

Valves Flange

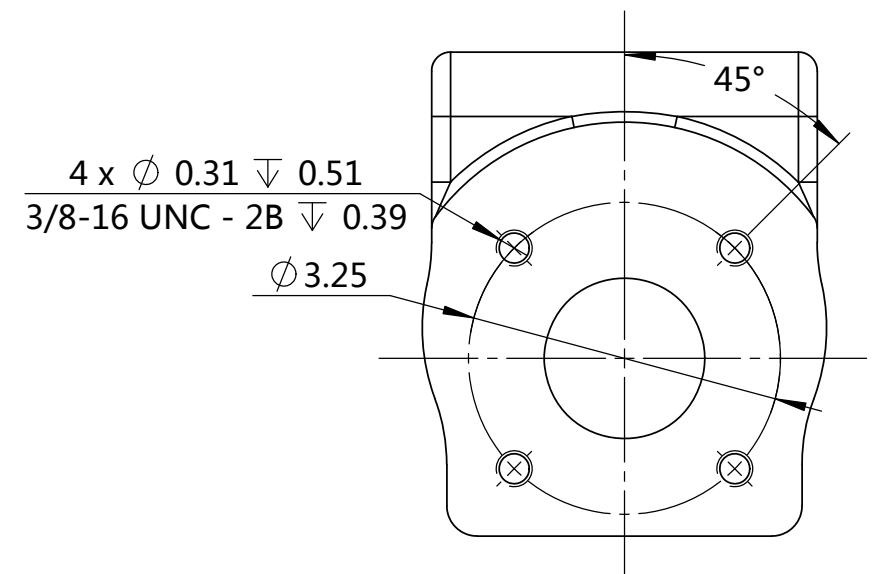

Wheel (Optional)

Wheel (Standard)

**Stem and Key
2"-6"**

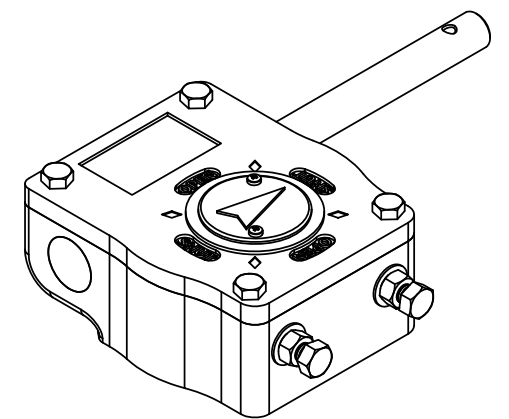
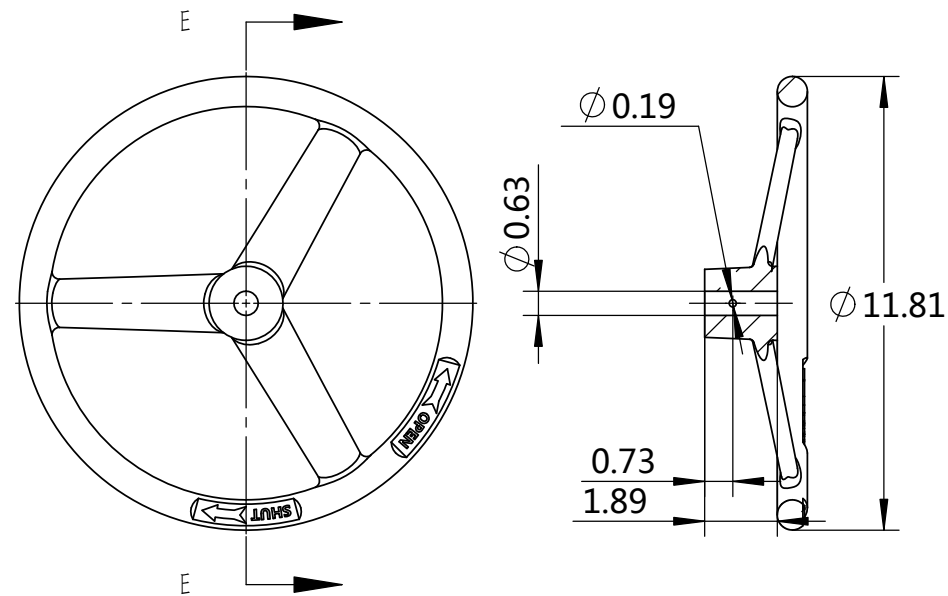
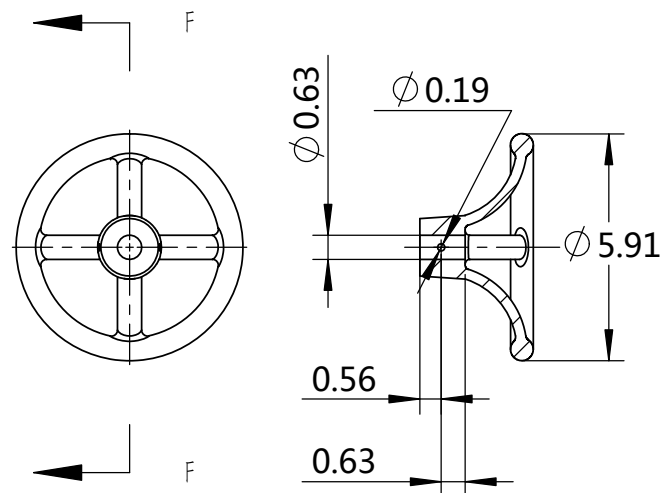
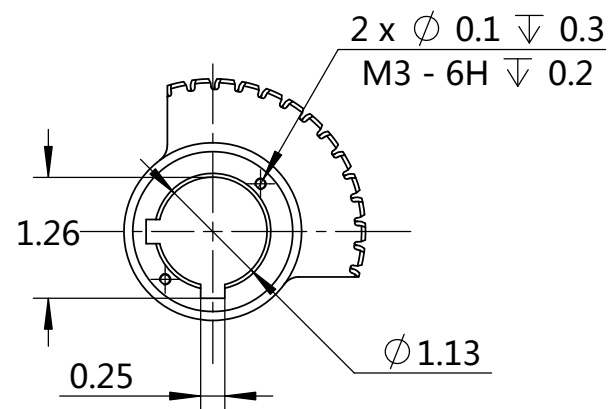

Mod.	Valves	Techical Data	
EM 10	PRATT 2"-6"	Max. Output Torque (lbf-in)	3540
		Max. Input Torque (lbf-in)	354
		Ratio	37:1
		Weight (Kg)	3.6 Kg

PROJECT NAME: Gears		Material:		 Pratt Industrial 3700 Oakes Drive, Suite B Emporia, KS 66801
DESIGN	SIGNATURE	DATE	WEIGHT: Kg	
DRAW		10/06/14	Q.A:	TITLE: Gears Drawing
CHK'D			Phase marker	DWG NO. EM 10-00
CRAFT			A	A3
APPR			REV:	SCALE: 1:2
				PAGE: 1 OF 1