

Stem and Key 14"-16"

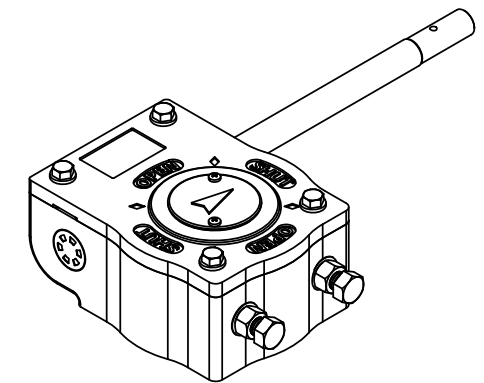
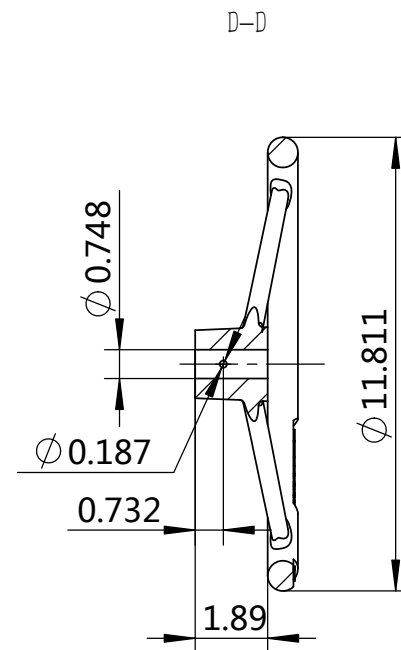
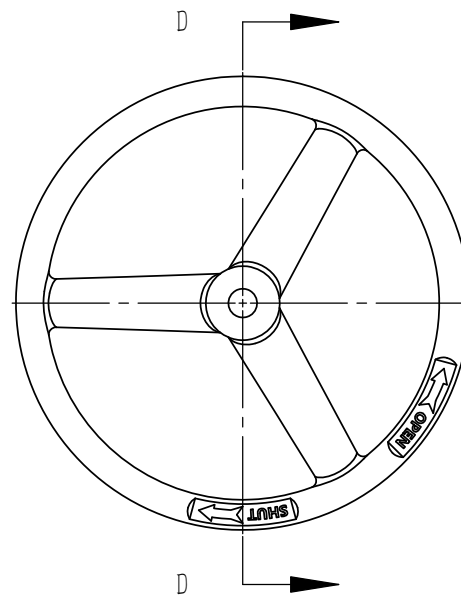
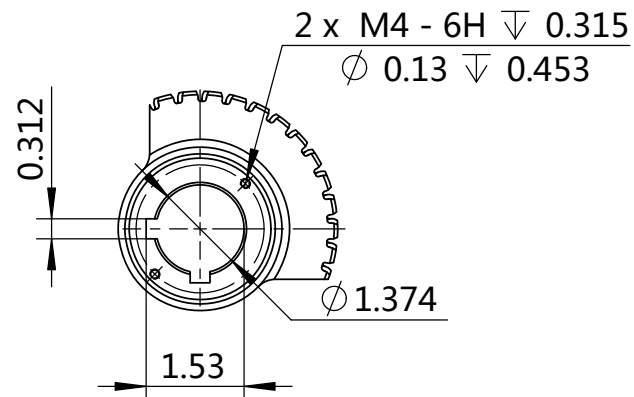

Mod.	Valves	Techical Data	
EM 30	PRATT 14"-16"	Max. Output Torque (lbf-in)	8850
		Max. Input Torque (lbf-in)	730
		Ratio	34:1
		Weight	9.3 Kg

PROJECT NAME: Gears		Material:		 Pratt Industrial 3700 Oakes Drive, Suite B Emporia, KS 66801
SIGNATURE	DATE	WEIGHT: Kg		
DESIGN	10/06/14	Q.A:		TITLE: Gear Drawing
DRAW		Phase marker		DWG NO. EM30-00
CHK'D		A		A3
CRAFT		REV:		SCALE: 1:5
APPR				PAGE: 1 OF 1